

CX145CSR
Tier 4
Crawler Excavator

SERVICE MANUAL

Part number 47395870A

1st edition English

July 2012





Section

1001

Safety, general information and standard torque data

CONTENTS

GENERAL INFORMATION.....	3
Safety.....	4
ROPS Judgment Method.....	6
Bolt and Nut Tightening.....	10

**Thanks very much for your reading,
Want to get more information,
Please click here, Then get the complete
manual**

JustClickHere 

NOTE:

**If there is no response to click on the link above,
please download the PDF document first, and then
click on it.**

**Have any questions please write to me:
admin@servicemanualperfect.com**

Safety, general information and standard torque data

GENERAL INFORMATION

CLEANING

Clean all metal parts except bearings, in a suitable cleaning solvent or by steam cleaning.

Do not use caustic soda for steam cleaning.

After cleaning, dry and put oil on all parts.

Clean oil passages with compressed air.

Clean bearings in a suitable cleaning solvent, dry the bearings completely and put oil on the bearings.

INSPECTION

Check all parts when the parts are disassembled.

Replace all parts that have wear or damage.

Small scoring or grooves can be removed with a hone or crocus cloth.

Complete a visual inspection for indications of wear, pitting and the replacement of parts necessary to prevent early failures.

BEARINGS

Check bearings for easy action.

If bearings have a loose fit or rough action replace the bearing.

Wash bearings with a suitable cleaning solvent and permit to air dry.

DO NOT DRY BEARINGS WITH COMPRESSED AIR.

NEEDLE BEARINGS

Before you press needle bearings in a bore always remove any metal protrusions in the bore or edge of the bore.

Before you press bearings into position put petroleum jelly on the inside and outside diameter of the bearings.

GEARS

Check all gears for wear and damage.

Replace gears that have wear or damage.

Oil seals, O-rings and gaskets.

Always install new oil seals, O-rings and gaskets.

Put petroleum jelly on seals and O-rings.

SHAFTS

Check all shafts that have wear or damage.

Check the bearing and oil seal surfaces of the shafts for damage.

SERVICE PARTS

Always install genuine Case service parts.

When ordering refer to the

Parts Catalogue for the correct part number of the genuine Case replacement items.

Failures due to the use of other than genuine Case replacement parts are not covered by warranty.

LUBRICATION

Only use the oils and lubricants specified in the Operator's or Service Manuals.

Failures due to the use of non-specified oils and lubricants are not covered by warranty.

Safety, general information and standard torque data

Safety

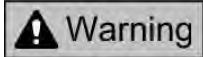

This symbol means ATTENTION! BECOME ALERT! YOUR SAFETY IS INVOLVED. The message that follows the symbol contains important information about safety. Carefully read the message. Make sure you fully understand the causes of possible injury or death.

To prevent injury always follow the Warning, Caution and Danger notes in this section and throughout the manual. Put the warning tag shown below on the key for the key switch when servicing or repairing the machine. One warning tag is supplied with each machine. Additional tags are available from your service parts supplier.

⚠ WARNING

Read the operator's manual to familiarize yourself with the correct control functions.

⚠ WARNING

Operate the machine and equipment controls from the seat position only. Any other method could result in serious injury.

⚠ WARNING

This is a one man machine, no riders allowed.

⚠ WARNING

**Before starting engine, study Operator's Manual safety messages.
Read all safety signs on machine.
Clear the area of other persons.
Learn and practice safe use of controls before operating.
It is your responsibility to understand and follow manufacturers instructions on machine operation, service and to observe pertinent laws and regulations.
Operator's and Service Manuals may be obtained from your CASE dealer.**

⚠ WARNING

**If you wear clothing that is too loose or do not use the correct safety equipment for your job, you can be injured.
Always wear clothing that will not catch on objects.
Extra safety equipment that can be required includes hard hat, safety shoes, ear protection, eye or face protection, heavy gloves and reflector clothing.**

⚠ WARNING

When working in the area of the fan belt with the engine running, avoid loose clothing if possible, and use extreme caution.

⚠ WARNING

When doing checks and tests on the equipment hydraulics, follow the procedures as they are written. DO NOT change the procedure.

⚠ WARNING

When putting the hydraulic cylinders on this machine through the necessary cycles to check operation or to remove air from a circuit, make sure all people are out of the way.

⚠ WARNING

Use insulated gloves or mittens when working with hot parts.

Safety, general information and standard torque data

⚠ WARNING

Lower all attachments to the ground or use stands to safely support the attachments before you do any maintenance or service.

⚠ WARNING

Pin sized and smaller streams of hydraulic oil under pressure can penetrate the skin and result in serious infection.

If hydraulic oil under pressure does penetrate the skin, seek medical treatment immediately.

Maintain all hoses and tubes in good condition.

Make sure all connections are tight.

Make a replacement of any tube or hose that is damaged or thought to be damaged.

DO NOT use your hand to check for leaks, use a piece of cardboard or wood.

⚠ WARNING

When removing hardened pins such as a pivot pin, or a hardened shaft, use a soft head (brass or bronze) hammer or use a driver made from brass or bronze and a steel head hammer.

⚠ WARNING

When using a hammer to remove and install pivot pins or separate parts using compressed air or using a grinder, wear eye protection that completely encloses the eyes (approved goggles or other approved eye protectors).

⚠ WARNING

Use suitable floor (service) jacks or chain hoist to raise wheels or tracks off the floor.
Always block machine in place with suitable safety stands.

⚠ WARNING

When servicing or repairing the machine, keep the shop floor and operator's compartment and steps free of oil, water, grease, tools, etc.

Use an oil absorbing material and/or shop cloths as required.

Use safe practices at all times.

⚠ WARNING

Some components of this machine are very heavy.
Use suitable lifting equipment or additional help as instructed in this Service Manual.

⚠ WARNING

Engine exhaust fumes can cause death.

If it is necessary to start the engine in a closed place, remove the exhaust fumes from the area with an exhaust pipe extension.

Open the doors and get outside air into the area.

⚠ WARNING

When the battery electrolyte is frozen, the battery can explode if (1), you try to charge the battery, or (2), you try to jump start and run the engine.

To prevent the battery electrolyte from freezing, try to keep the battery at full charge.

If you do not follow these instructions, you or others in the area can be injured.

Safety, general information and standard torque data

ROPS Judgment Method

1. Purpose

Check against the ROPS judgment criteria to judge whether the machine satisfies the ROPS criteria or not. The weight and boom of the machine greatly effects whether the ROPS judgment criteria is satisfied or not. The ROPS test assumes that the weight being used is the weight of the machine when the maximum number of selectable options are mounted (as of 2009).

However, depending on the derivative machinery or the order details, the weight and boom position may differ from the assumed weight or position.

2. Criteria for judging whether a machine satisfies the ROPS criteria

1) Weight

The weight must not be over the weight shown below for each class.

If the weight is exceeded, there is a danger that the cab could be damaged and the operator could die or sustain a serious injury when the machine falls over.

If the weight exceeds the stipulated weight, the machine will not satisfy the ROPS criteria.

• Weight (X3 model)

To satisfy the ROPS criteria, the weight must not be over the indicated weight. (The below weights are the weights indicated on the nameplate within the ROPS cab)

Machine body total weight	Class
16000 kg (35274.146 lb) or less	CX75C CX145C
20500 kg (45195.000 lb) or less	CX130C CX160C CX180C
28000 kg (61729.756 lb) or less	CX235C
31000 kg (68343.658 lb) or less	CX210C CX250C CX250C LR CX300C
40000 kg (88185.365 lb) or less	CX370C
50000 kg (110231.707 lb) or less	CX470C

* The ROPS test assumes that the CX470C has a cage guard (alone).

Machine body total weight	Class
16000 kg (35274.146 lb) or less	CX75C CX145C
20500 kg (45195.000 lb) or less	CX130C CX160C CX180C
28000 kg (61729.756 lb) or less	CX235C
31000 kg (68343.658 lb) or less	CX210C CX250C CX250C LR CX300C
50000 kg (110231.707 lb) or less	CX470C

* The ROPS test assumes that the CX470C has a cage guard (alone).

• Weight (X2 model)

To satisfy the ROPS criteria, the weight must not be over the indicated weight. (The below weights are the weights indicated on the nameplate within the ROPS cab)

Machine body total weight	Class
26600 kg (58643.268 lb) or less	CX130B CX160B CX180B CX210B CX240B

Safety, general information and standard torque data

2) Boom position

⚠ WARNING

- If the machine has been modified so that the boom position has been lowered, the machine will not satisfy the ROPS criteria.
- It is necessary to consult with our company if it is possible that the boom's position has been lowered by modification.
- The extent to which a boom position has moved cannot be determined in the same way for all machines.

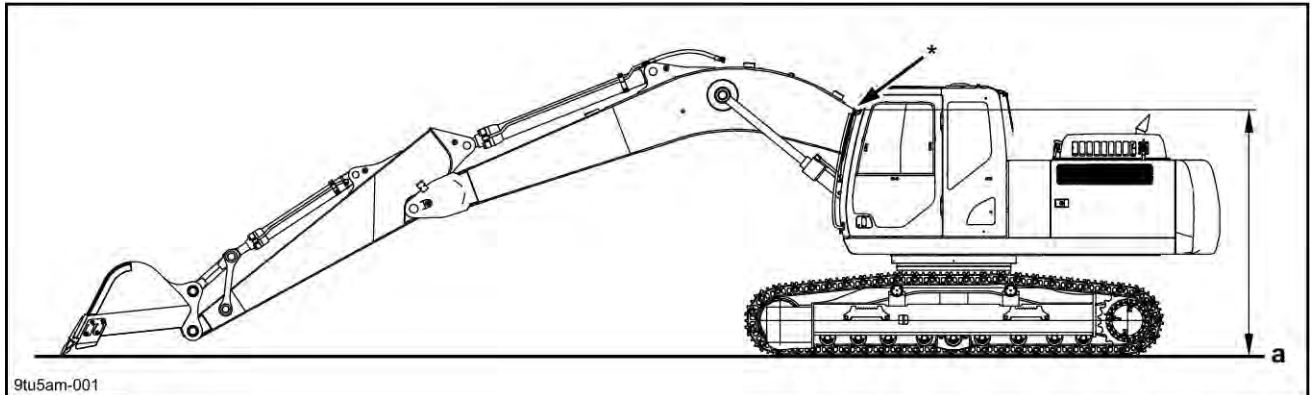

a | Ground point

With the tip of the bucket in contact with the ground surface at maximum work radius, if the position (* in the diagram) that overlaps with the cab when viewed from the side is markedly lower than that of a standard machine (standard arm), the machine will not satisfy the ROPS criteria.

Also, with a machine body with a cab mounted that can withstand up to 31 tons, the effect of mounting a 24 ton machine, which is near the restriction weight, and a 21 ton machine to the same cab will not be the same.

3. Prohibited items

- Modifications that reduce the strength of a platform that has a cab with a ROPS mounted to it. (Actions or modifications that reduce the functionality of the anchoring part at the left-rear of the cab)
- Modifications that effect the strength of the ROPS of a cab.

A forbidden all modifications (red part)	All modifications (grinding, welding, drilling holes, removing, etc.) are prohibited.
Allow under specified conditions (gray part)	Removal of parts is prohibited. Bar welding and making holes [up to diameter 20 mm (0.787 in)] by drilling are possible.

Safety, general information and standard torque data

[X3 Cab (CX130C/CX160C/CX180C)]

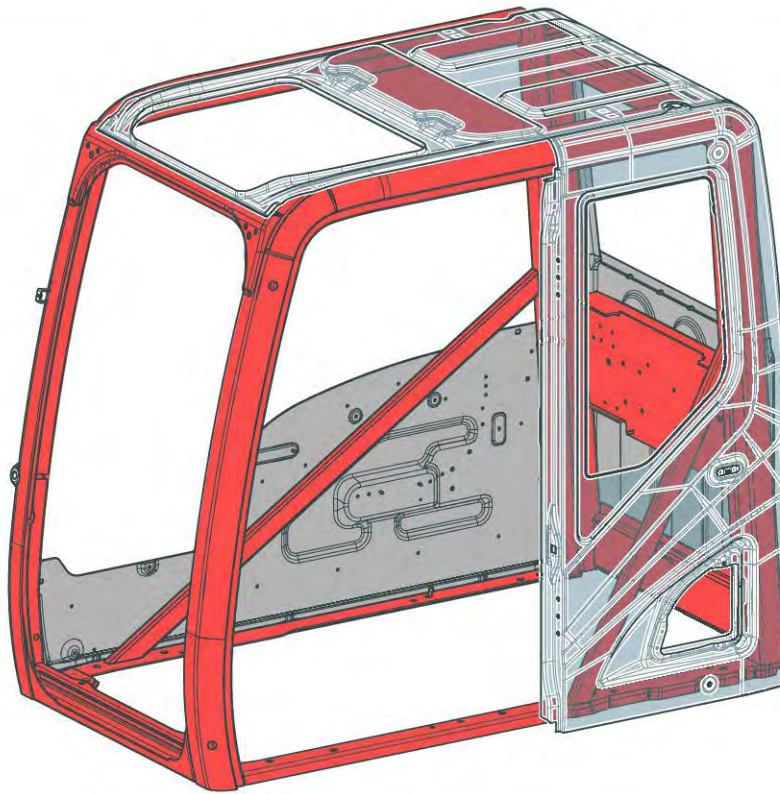

35D6802C

[X3 Cab (CX210C/CX240C/CX290C)]

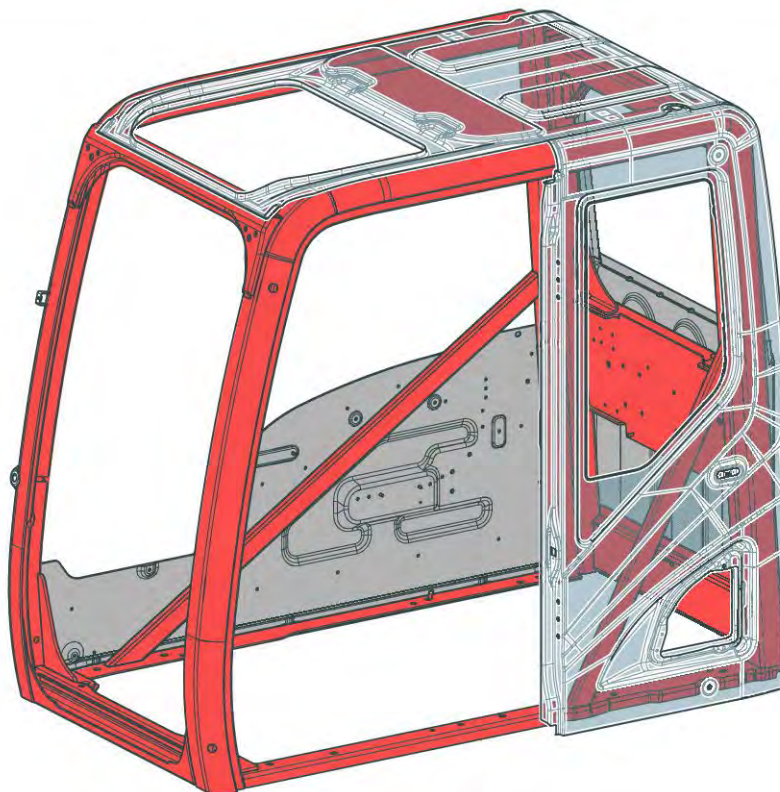

6D4C4E87

Safety, general information and standard torque data

[X2 Cab (CX210B/CX240B/CX290B)]

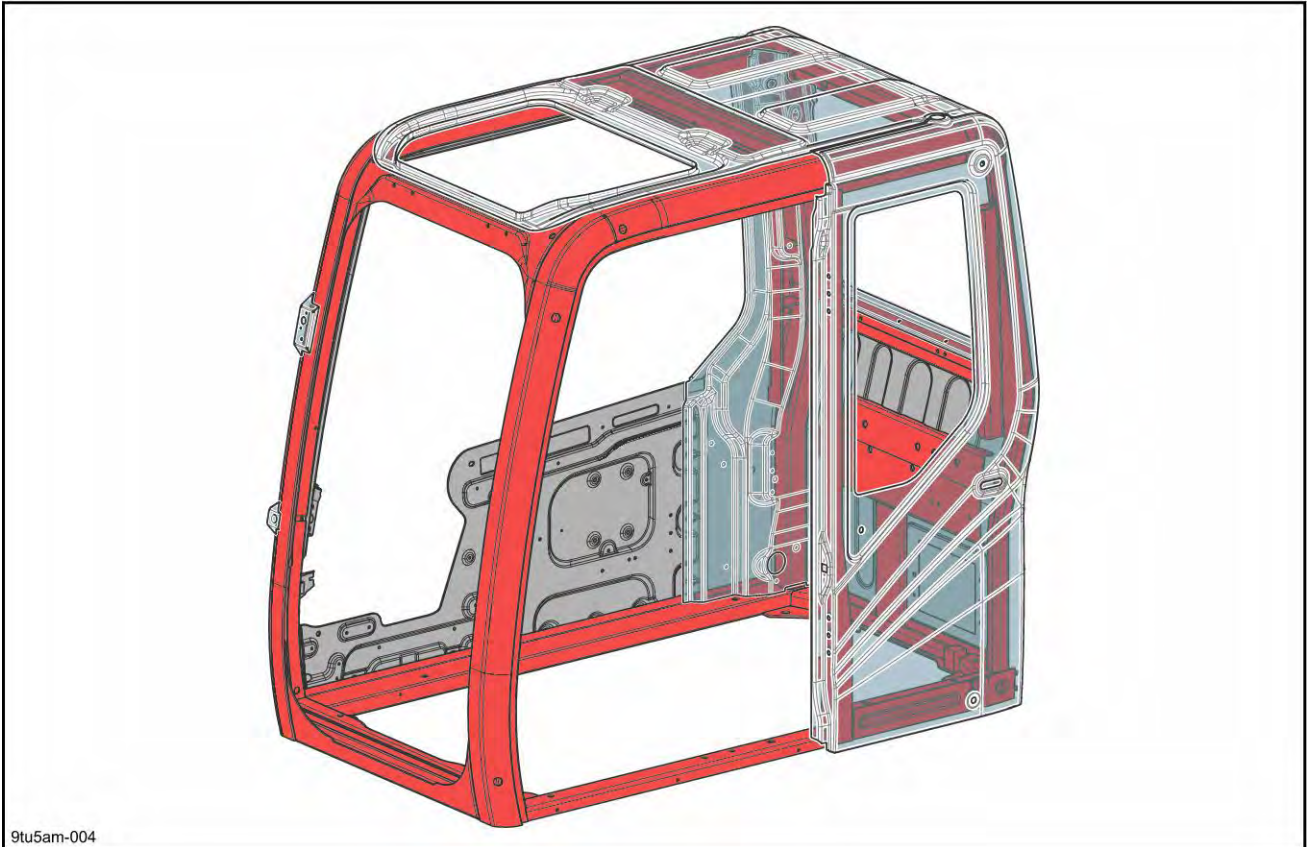

- In general, high cabs do not satisfy the ROPS criteria. (It is necessary to consult with our company to check if the high cab model satisfies the ROPS criteria.)

Safety, general information and standard torque data

Bolt and Nut Tightening

- Tighten alternating between left and right and top and bottom so that uniform tightening force is applied.

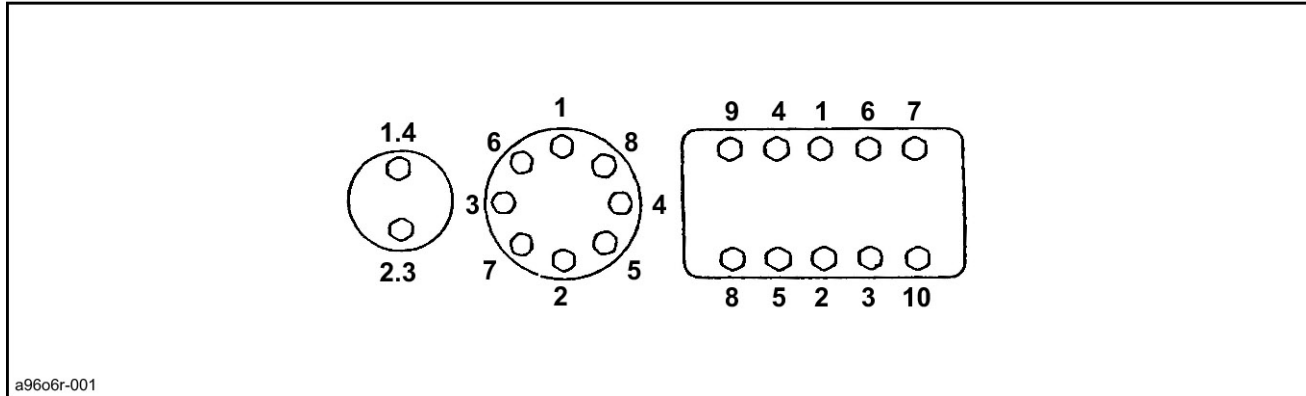

a96o6r-001

- If Loctite was used on a removed bolt (there is something white sticking to the bolt when it is removed), clean the old Loctite off with cleaning fluid, dry the bolt, then apply 2 - 3 drops of Loctite to the thread section of the bolt.

Torque table

Bolt nominal diameter (size)			M6	M8	M10	M12	M14	M16	M18	M20
Hexagon bolt	Wrench	mm (in)	10 (0.394)	13 (0.512)	17 (0.669)	19 (0.748)	22 (0.866)	24 (0.945)	27 (1.063)	30 (1.181)
	Tightening torque	N·m (lbf·ft)	6.9 (5.090)	19.6 (14.459)	39.2 (28.917)	58.8 (43.376)	98.1 (72.367)	156.9 (115.743)	196.1 (144.661)	294.2 (217.028)
Hexagon socket head bolt	Wrench	mm (in)	5 (0.197)	6 (0.236)	8 (0.315)	10 (0.394)	12 (0.472)	14 (0.551)	14 (0.551)	17 (0.669)
	Tightening torque	N·m (lbf·ft)	8.8 (6.492)	21.6 (15.934)	42.1 (217.028)	78.5 (57.909)	117.7 (86.826)	176.5 (130.202)	245.2 (180.881)	343.2 (253.175)



Section

1002A

Specifications

CONTENTS

CX145C	3
Main Data	3
Performance	3
Main Unit Dimensions	3
Engine	4
Cooling System	4
Upper Side Work System	4
Operating Device	5
Swing Units	5
Travel Lower Body	5
Hydraulic Equipment	6
Hydraulic Device	6
Control Valve and Cylinder	6
Capacities, Filters	6
Coolant and Oil Capacities	6
Hydraulic Oil Filters	6
Fuel Filter	6
CX145C LC	7
Main Data	7
Performance	7
Main Unit Dimensions	7
Engine	8
Cooling System	8
Upper Side Work System	8
Operating Device	9
Swing Units	9
Travel Lower Body	9
Hydraulic Equipment	10
Hydraulic Device	10
Control Valve and Cylinder	10
Capacities, Filters	10
Coolant and Oil Capacities	10
Hydraulic Oil Filters	10
Fuel Filter	11
CX145C (Blade)	12
Main Data	12
Performance	12
Main Unit Dimensions	12
Engine	13
Cooling System	13
Upper Side Work System	13
Operating Device	14
Swing Units	14
Travel Lower Body	14
Hydraulic Equipment	15
Hydraulic Device	15
Control Valve and Cylinder	15
Capacities, Filters	15

Coolant and Oil Capacities	15
Hydraulic Oil Filters	15
Fuel Filter	16

Specifications

CX145C

Main Data

Operating weight	14100 kg (31085.341 lb)
Engine output	74.9 kW/2000 min ⁻¹ (100.443 HP/2000 rpm)
Bucket capacity	Heaped 0.487 m ³
	Leveled 0.366 m ³

Performance

Standard weight	6.6 kN (1483.993 lbf)
Swing speed	10.6 min ⁻¹ (10.6 rpm)
Travel speed	Low speed 3.4 km/h (2.1127 mile/h)
	High speed 5.6 km/h (3.4797 mile/h)
Maximum pulling force	116 kN (26082.30 lbf)
Grade ability	70 % (35 °)
Ground pressure	46 kPa (6.67 psi) [500 mm (19.685 in) grouser shoe]
	38 kPa (5.51 psi) [600 mm (23.622 in) grouser shoe]
	33 kPa (4.79 psi) [700 mm (27.559 in) grouser shoe]

Standard weight	6.6 kN (1483.993 lbf)
Swing speed	10.6 min ⁻¹ (10.6 rpm)
Travel speed	Low speed 3.4 km/h (2.1127 mile/h)
	High speed 5.6 km/h (3.4797 mile/h)
Maximum pulling force	116 kN (26082.30 lbf)
Grade ability	70 % (35 °)
Ground pressure	46 kPa (6.67 psi) [500 mm (19.685 in) grouser shoe]
	38 kPa (5.51 psi) [600 mm (23.622 in) grouser shoe]
	32 kPa (4.64 psi) [700 mm (27.559 in) grouser shoe]

Main Unit Dimensions

Main unit length	3500 mm (137.795 in)
Main unit width	2590 mm (101.969 in)
Upper swing body width	2490 mm (98.031 in)
Cab width	1000 mm (39.370 in)
Main unit height	2900 mm (114.173 in)
Swing radius (rear end)	1490 mm (58.661 in)
Swing body rear end distance	1490 mm (58.661 in)
Swing body rear section bottom height	880 mm (34.646 in)
Distance between tumblers	2790 mm (109.843 in)
Overall track length	3500 mm (137.795 in)
Overall track width	2590 mm (101.969 in)
Distance between tracks	1990 mm (78.346 in)
Track shoe width	600 mm (23.622 in) [options 500 mm (19.685 in), 700 mm (27.559 in)]
Minimum ground clearance	440 mm (17.323 in) (to bottom of lower frame)

Main unit length	3500 mm (137.795 in)
Main unit width	2590 mm (101.969 in)
Upper swing body width	2490 mm (98.031 in)
Cab width	1000 mm (39.370 in)
Main unit height	2800 mm (110.236 in)
Swing radius (rear end)	1550 mm (61.024 in)
Swing body rear end distance	1550 mm (61.024 in)
Swing body rear section bottom height	880 mm (34.646 in)
Distance between tumblers	2790 mm (109.843 in)
Overall track length	3500 mm (137.795 in)

Specifications

Overall track width	2590 mm (101.969 in)
Distance between tracks	1990 mm (78.346 in)
Track shoe width	600 mm (23.622 in) [options 500 mm (19.685 in), 700 mm (27.559 in)]
Minimum ground clearance	440 mm (17.323 in) (to bottom of lower frame)

Engine

Name	Isuzu 4JJ1X diesel engine
Model	4-cycle, water-cooled, overhead camshaft type, common rail system (electronic control), cooled EGR, with turbocharger (variable displacement type), DPD system
No. of cylinders - bore x stroke	4 - D95.4 mm (3.7559 in) x 104.9 mm (4.1299 in)
Total stroke volume	2.999 L (0.79227 gal)
Maximum torque	359 N·m/1600 min ⁻¹ (264.83 lbf·ft/1600 rpm)
Starter	24 V 4.0 kW reduction type
Charging generator	24 V 50 A AC type
Battery	12 V 72 Ah/5 HR x 2

Cooling System

Fan type	D550 mm (21.654 in) 8 blades, suction
Radiator	
Fin type	Wavy
Fin pitch	1.75 mm (0.06890 in)
Oil cooler	
Fin type	Wavy
Fin pitch	1.75 mm (0.06890 in)
Intercooler	
Fin type	Wavy
Fin pitch	2.0 mm (0.0787 in)
Fuel cooler	
Fin type	Wavy
Fin pitch	2.0 mm (0.0787 in)

Upper Side Work System

Model	Backhoe attachment		
Components, dimensions, working dimensions			
Standard bucket capacity	Heaped 0.487 m ³ (Leveled 0.366 m ³)		
Bucket width	898 mm (35.354 in)		
Bucket width with side cutter	972 mm (38.268 in)		
Bucket weight with side cutter	389.6 kg (858.9255 lb)		
Boom length	4630 mm (182.283 in)		
Arm type	Standard [2.50 m (8.2021 ft)]	Long [3.01 m (9.8753 ft)]	Short [2.11 m (6.9226 ft)]
Arm length	2500 mm (98.425 in)	3010 mm (118.504 in)	2110 mm (83.071 in)
Bucket radius	1200 mm (47.244 in)		
Bucket wrist angle	178°		
Maximum digging radius	8290 mm (326.378 in)	8740 mm (344.094 in)	7940 mm (312.598 in)
Maximum digging radius at ground line	8140 mm (320.472 in)	8600 mm (338.583 in)	7780 mm (306.299 in)
Maximum digging depth	5510 mm (216.929 in)	6010 mm (236.614 in)	5110 mm (201.181 in)
Maximum vertical straight wall digging depth	4900 mm (192.913 in)	5280 mm (207.874 in)	4560 mm (179.528 in)

Specifications

Maximum digging height	9340 mm (367.717 in)	9690 mm (381.496 in)	9060 mm (356.693 in)
Maximum dump height	6940 mm (273.228 in)	7290 mm (287.008 in)	6660 mm (262.205 in)
Minimum swing radius at front	1950 mm (76.772 in)	2330 mm (91.732 in)	1890 mm (74.409 in)
Height for minimum swing radius at front	6820 mm (268.504 in)	6840 mm (269.291 in)	6820 mm (268.504 in)

Operating Device

Operator's seat		
Position	Left side	
Structure	Adjustable forward and back and up and down, reclining mechanism, with seat suspension	
Cab		Sealed steel type, all reinforced glass
Levers and pedals		
For travel use	Lever and pedal type (hydraulic pilot type) x 2	
For operating machine use	Lever type (hydraulic pilot type) x 2	
Instruments and switches		
Work mode switchover		3 modes (SP/H/A)
Travel mode switchover	Low-speed/high-speed switch type	
One-touch idle	Knob switch type	
Engine emergency stop	Switch type	
Monitor device		
Machine status display (full color liquid crystal)		
Work mode select status	SP/H/A	
Instruments (full color liquid crystal)		
Fuel gauge	Bar graph and indicator	
Engine coolant temperature gauge	Bar graph and indicator	
Hydraulic oil temperature gauge	Bar graph and indicator	
Hour meter	Digital type	
Machine status and warnings (full color liquid crystal and warning alarm) * has warning alarm		
Overheat (*) Battery charge (*) Electrical system abnormality (*) Refill fuel (*) Engine oil pressure (*) Refill coolant (*) Engine pre-heat Auto warm up Air cleaner (*) Anti-theft device triggered Engine system abnormality (*) Engine emergency stop (*)		
Illumination equipment		
Working light	Tank front surface	24 V 70 W x 1
	Cab top	24 V 70 W x 2
	Boom up	24 V 70 W x 1
Interior light	24 V 10 W x 1	
Horn		Electric horn x 2
Other		Wiper with intermittent function, window washer, air conditioner, clock, rear view mirrors (left and right, total of 4)

Swing Units

Swing circle	Swing bearing type (with inner gear)
Swing hydraulic motor	Fixed displacement piston motor x 1
Reduction gear	Planetary gear 2-stage reduction gear
Swing parking brake	Mechanical lock (operational lever linkage type)

Travel Lower Body

Travel hydraulic motor	Variable displacement piston motor x 2
Reduction gear	Planetary gear 2-stage reduction gear
Travel brake	Hydraulic lock
Parking brake	Mechanical lock (travel lever linkage type)
Track shoe	

Specifications

Model	Assembly-type triple grouser shoe
No. of shoes (per side)	600G with seal, 500G, 500L with seal, 700G with seal: 46 (BH) 600G with seal, 500G, 500L with seal, 700G with seal: 43(BA / BB)
Shoe width	600 mm (23.622 in) [options 500 mm (19.685 in), 700 mm (27.559 in)]
Grouser height	20 mm (0.787 in)
Link pitch	171.5 mm (6.7520 in)
Roller	
No. of upper rollers (per side)	1
No. of lower rollers (per side)	7
Track belt tension adjuster	Grease cylinder type (with cushion spring)

Hydraulic Equipment

Hydraulic Device

Hydraulic pump drive type	Direct engine link (no transmission)
Hydraulic pump	
Model	Double variable displacement piston pump x 1 Gear pump x 1
Discharge volume	Piston pump 2 x 129 L/min (34.079 gpm) Gear pump 20 L/min (5.284 gpm)
Pump control method	Simultaneous output full-horsepower control
Set pressure of main relief valve	34.3 MPa (4975.341 psi) [36.3 MPa (5265.45 psi) for pressure boost]
Set pressure of overload relief valve	32.3 MPa (4685.234 psi) (boom down) 38.2 MPa (5541.050 psi) (other)

Control Valve and Cylinder

Control valve	
Model	Quadruple spool Quintuple spool
Operating method	Hydraulic pilot type: travel, swing, and operating machine
Cylinder	No. of cylinders x tube bore - rod diameter - stroke
Boom cylinder	2 x D105 mm (D4.134 in) - D75 mm (D2.953 in) - 1120 mm (44.094 in)
Arm cylinder	1 x D115 mm (D4.528 in) - D80 mm (D3.150 in) - 1108 mm (43.622 in)
Bucket cylinder	1 x D95 mm (D3.740 in) - D65 mm (D2.559 in) - 881 mm (34.685 in)

Capacities, Filters

Coolant and Oil Capacities

Coolant	15.3 L (4.042 gal)
Fuel	200 L (52.84 gal)
Engine lubricating oil	17 L (4.49 gal)
Travel reduction gear lubricating oil (one side)	2.1 L (0.555 gal)
Swing reduction gear lubricating oil	3.0 L (0.793 gal)
Hydraulic oil	158 L (41.74 gal)
Hydraulic oil tank regulation amount	75 L (19.81 gal)

Hydraulic Oil Filters

Suction filter (inside tank)	105 µm
Return filter (inside tank)	6 µm
Pilot line filter (inside housing)	8 µm

Fuel Filter

Main filter	2 µm
Pre-filter	5.5 µm